

# PVS-SJ

## POWER VISE (STEP JAW TYPE)

- Step-jaw precision power vise with adjustable torque

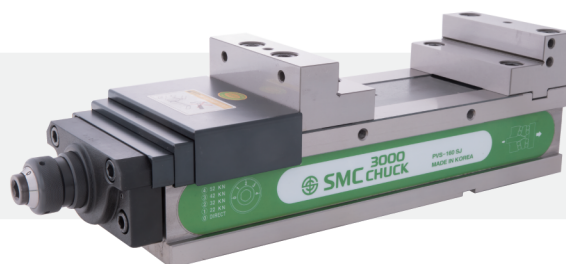

## Outward Drawing

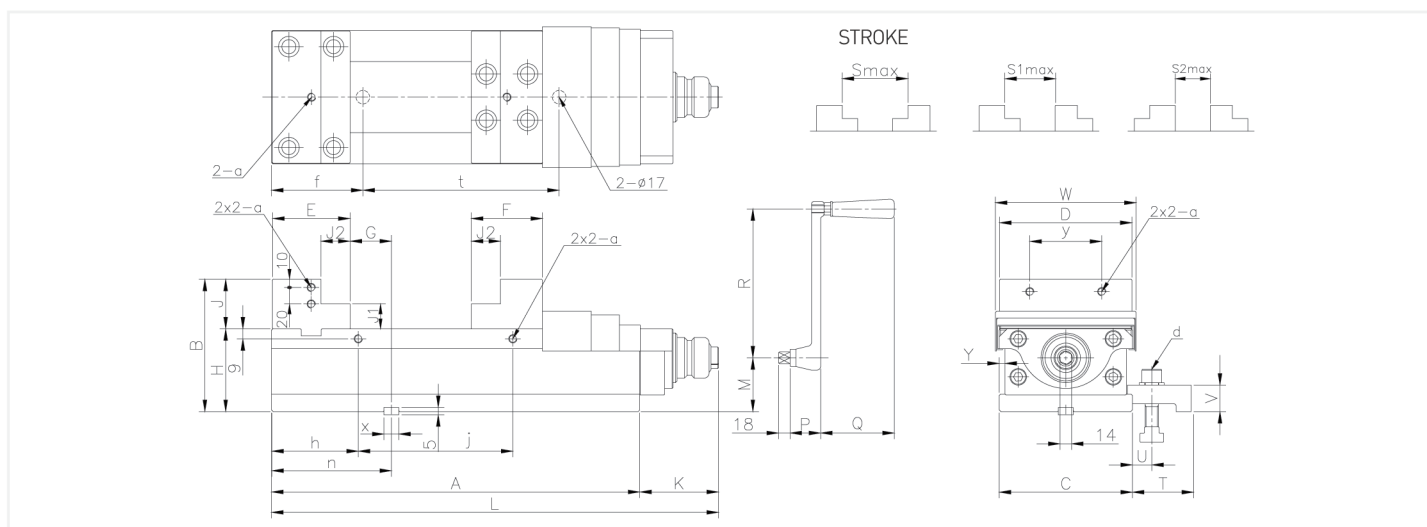

## Dimensions

[UNIT : mm]

Model	A	B	C	D	E	F	G	H	J	J1	J2	K	L	M	N	P	Q	R	S	S1
PVS-160SJ(6")	490	160	161	160	94	86	50	100	60	30	50	99	589	65	21	37	95	180	400	350
PVS-200SJ(8")	533	180	202	200	102	98	74	110	70	35	50	99	632	75	21	37	95	180	420	370

Model	S2	T	U	V	W	X	Y	a	b	f	g	h	j	n	r	t	y	Weight(kg)
PVS-160SJ(6")	300	72	15~31	30	170	18	6	M10	M16X65	100	12	105	140	145	444	265	100	65
PVS-200SJ(8")	320	72	15~31	30	214	18	7	M10	M16X65	100	12	125	140	177	455	350	120	100

## Specifications

[UNIT : mm]

Model	Jaw Width	Jaw Height	Max. Opening	Total Height	Silder Height	Total Width	Total Length	Max. Gripping Force KN(kgf)	Weight (kg)
PVS-160SJ(6")	160	60	400	160	100	170	589	60[6122]	65
PVS-200SJ(8")	200	70	420	180	110	214	632	60[6122]	100